

Description		Assembly Order No.
Style 110	Blind nuts, 1/4 NPT	W01-358-7451
	Blind nuts, 3/4 NPT	W01-358-7484
Two Ply Bellows	Socket head aluminum bead rings (bolts, nuts, washers not included-use 1/4 cap screws)	W01-358-0112
	Rubber bellows only	W01-358-0100
Assembly weight		3.0 lbs.
Force to collapse to minimum height (@ 0 PSIG).....		8 lbs.

Recommended Design Position Static Pressure 0-100 psi

RECOMMENDED AIRMOUNT DESIGN HEIGHT 4.5 INCHES

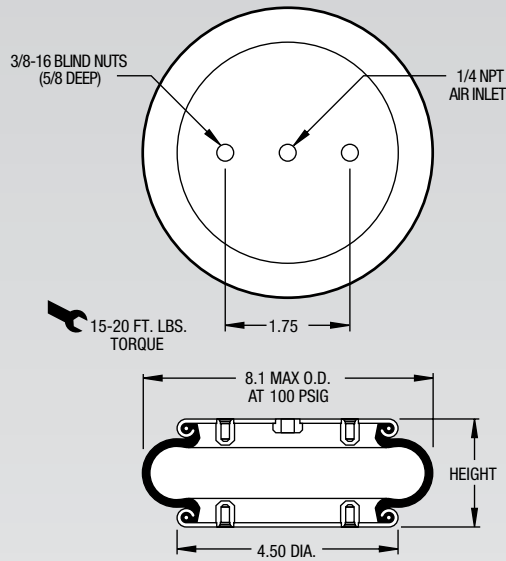

NOTE: A bead plate part is shown. This part is also available with bead rings. Bolts are not included. See pages 8-10 for explanation.

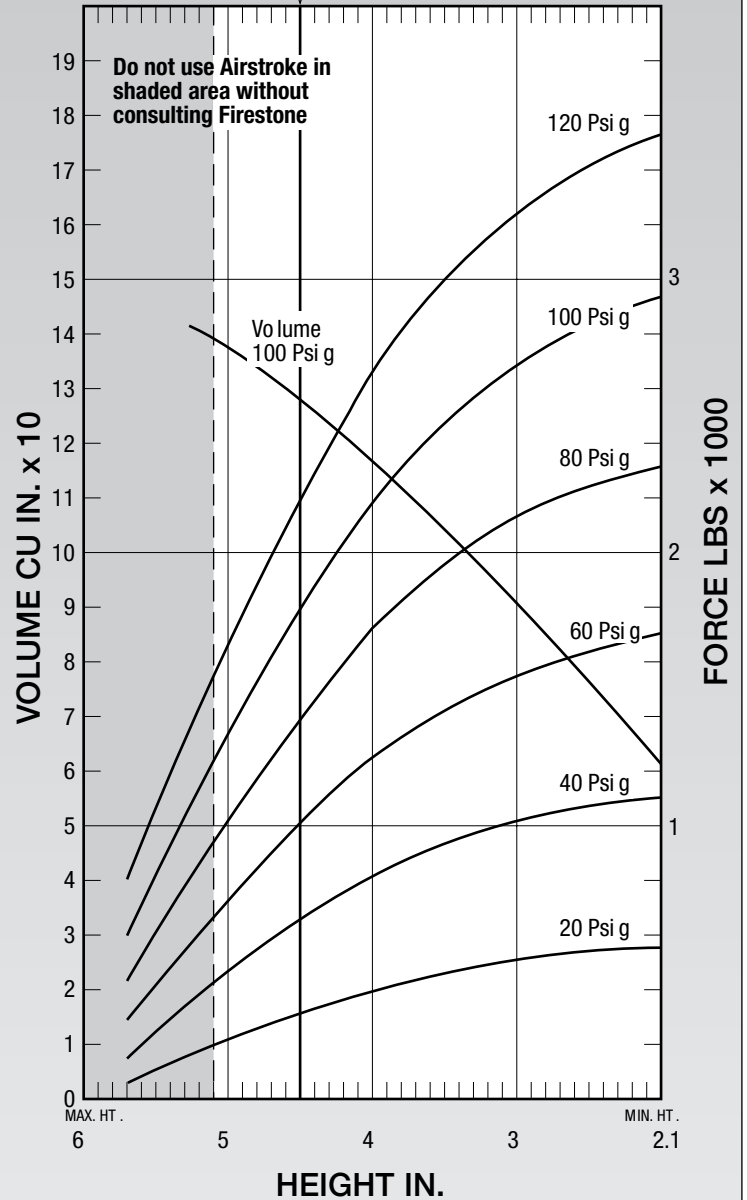

See page 12 for instructions on how to use chart.

Dynamic Characteristics at 4.5 in. Design Height (Required for Airmount isolator design only)				
Volume @ 100 PSIG = 128 in ³			Natural Frequency	
Gage Pressure (PSIG)	Load (lbs.)	Spring Rate (lbs./in.)	CPM	HZ
40	650	554	173	2.88
60	1,010	795	167	2.77
80	1,390	1,046	162	2.71
100	1,790	1,294	160	2.66

Force Table (Use for Airstroke™ actuator design)						
Assembly Height (in.)	Volume @ 100 PSIG (in ³)	Pounds Force				
		@20 PSIG	@40 PSIG	@60 PSIG	@80 PSIG	@100 PSIG
4.0	117	390	810	1,240	1,700	2,160
3.0	91	490	1,010	1,540	2,090	2,650