

**REASON FOR UPDATE:**

- Installation and Fitment Requirements

IMPACTED PART NUMBERS:

- W217602625 – Ride Rite
- W217602716 – RED Label
- W217602845 – All In One Analog
- W217602854 – All In One Wireless

Applications	
Year	2017-2023
Make	Ford
Models	F250/F350/F450 (4WD)

Installation Update:

- If utilizing the 1.5" spacer (5336) during the installation of 2625, 2716, 2845, or 2854, install part number 2335820045 inside the spacer to fill the gap between the lower bracket and the spacer.
- Utilizing the puck will not require different hardware to secure the air spring to the lower bracket. See "Diagram 1".
- If your kit did not come with part number 2335820045, or if you need additional information, please contact tech support at: 800-888-0650 or email rrtech@fsip.com.

Installation Update:

- When securing the air springs to the lower brackets, use part number 3514 (1.0" Flat Head Cap Screws) when the 1.5" spacer (5336) is **not** being used.
- When using the 1.5" spacer (5336), use part number 3430 (2.0" Flat Head Cap Screws).
- **Do not** use the 1" Flange Bolt (3106) or the 2" Flange Bolt (3150) to secure the air spring to the lower bracket. Using the Flange Bolts will not allow the lower bracket (5938) to sit down on the jounce stop. See "Diagram 1":

Installation Update:

- When installing the lower bracket (5938) be sure that the bracket is sitting down on the jounce stop. See "Diagram 2":

For the most current installation instructions, please visit: <https://www.firestoneairide.com/kit-search/> and search by kit number or application.

Firestone AIRIDE



PRODUCT UPDATE

Installation Guide Update – 2625/2716/2845/2854

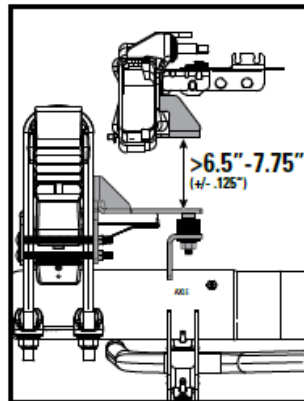
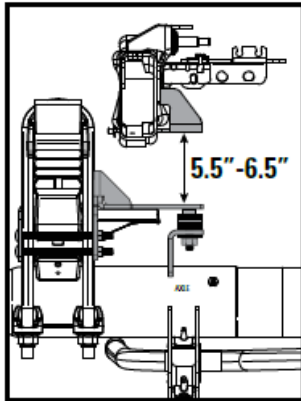

Diagram 1

Diagram 2

STANDARD INSTALLATION

INSTALLATION WITH SPACER



5.5\"-6.5\"

> 6.5\"-7.75\"

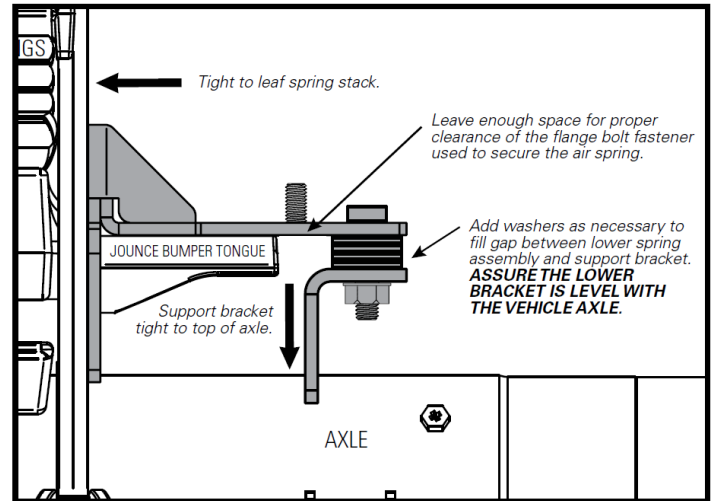
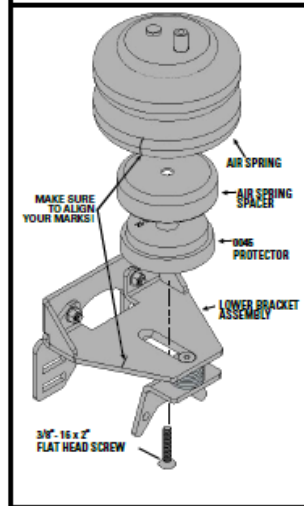
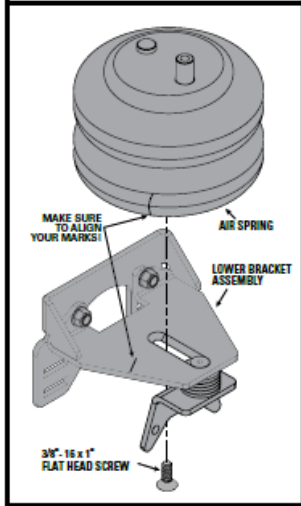

Firestone AIRIDE

Firestone Airide, a division of Firestone Industrial Products CO., LLC
Nashville, TN, www.firestoneairide.com
US Manufacturing Facilities: Dyersburg, TN • Williamsburg, KY
www.firestoneairide.com



@FirestoneAiride